

FMC257

Dual NVMe Solid State Drives, FMC
Storage and RS-485/422, Singled
Ended +3.3V

Key Features

- FMC Compact storage module
- FMC with dual NVMe type Solid State Drive (SSD)
- High performance with dual PCIe Gen3 x4 interface
- Self-Encrypting Drive (SED) option
- 8 x RS-485/RS422 TX with speed up to 20 Mbps
- 8 x RS-485/RS422 RX with speed up to 52 Mbps
- 8 x Singled-ended +3.3V input or output

Benefits

- High-performance solid-state storage
- Single Module to provide I/O
- Compact industry standard form factor
- Electrical, mechanical, software, and system-level expertise in house
- Full system supply from industry leader
- AS9100 and ISO9001 certified company



vadatech
THE POWER OF VISION



FMC257

The FMC257 is a storage module with dual NVMe storage SSD which provides high speed and low latency read/write. The module allows the FPGA to access a large capacity of storage in a compact space. The FMC257 interfaces to the carrier via dual PCIe x4 (DP0-3 and DP4-7).

The storage has option for SED which is hardware-based AES-256 Encryption engine.

Further the FMC257 provides eight RS-485/422 RX plus eight RS-485/422 TX, and eight single-ended +3.3V input or outputs (user configurable per I/O).

The RS-485/422 configuration can be selected as full-duplex RS-422 (independent RX/TX pairs with RX termination) or half-duplex RS-485 (RX/TX pairs tied together, no termination on board) based on the ordering option. The FMC257 can provide power of up to 12W to an external module.

Block Diagram

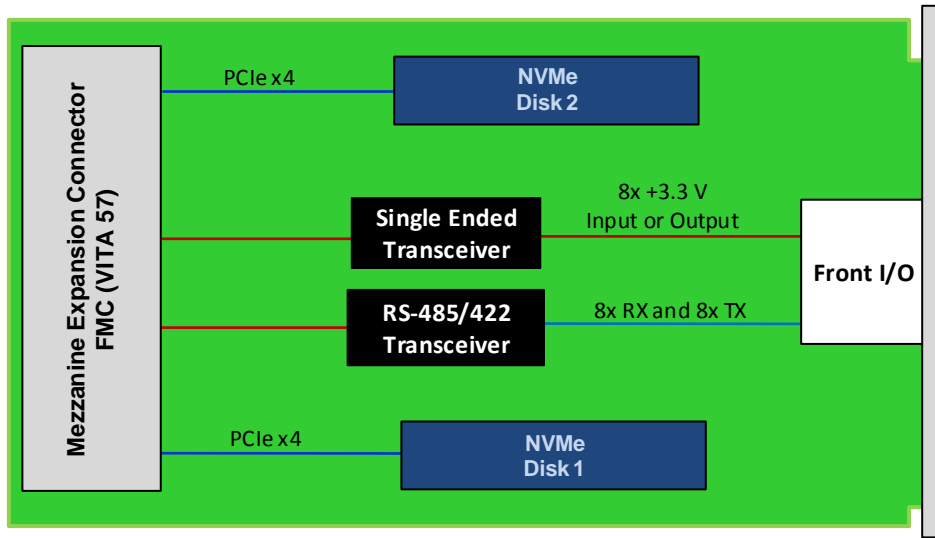

Figure 1: FMC257 Functional Block Diagram

Specifications

Architecture		
Physical	Dimensions	Single module
		Width: 2.71" (69 mm)
		Depth 3.01" (76.5 mm)
Type	FMC Storage	NVMe SSD with Multi I/O
Standards		
FMC	Type	ANSI/VITA 57.1 - 2008
Configuration		
Power	FMC257	~10W
Environmental	Temperature	See ordering options and environmental spec sheet
		Storage Temperature: -40° to +85°C
	Vibration	Operating 9.8 m/s ² (1G), 5 to 500 Hz on each axis
	Shock	Operating 30Gs each axis
	Relative Humidity	5 to 95% non-condensing
Front Panel	Interface Connectors	None
	LEDs	Activity
Software Support	Operating System	Not applicable
Other		
MTBF	MIL Hand book 217-F@ TBD hrs	
Certifications	Designed to meet FCC, CE and UL certifications, where applicable	
Standards	VadaTech is certified to both the ISO9001:2000 and AS9100B:2004 standards	
Warranty	Two (2) years	

INTEGRATION SERVICES AND APPLICATION-READY PLATFORMS

VadaTech has a full ecosystem of ATCA and MTCA products including chassis platforms, shelf managers, AMC modules, Switch and Payload Boards, Rear Transition Modules (RTMs), Power Modules, and more. The company also offers integration services as well as pre-configured Application-Ready Platforms. Please contact VadaTech Sales for more information.

Ordering Options

FMC257 – ABC-000-00J

A = Storage* 0 = 512 GB (total of 1 TB) 1 = 1 TB (total of 2 TB) 2 = Reserved 3 = Reserved		
B = SED 0 = No SED 1 = SED (TCG/Opal 2.0 Compliant)		
C = I/O configuration for RS-485/RS422 0 = Full-duplex (8 RS-422 RS w/termination and 8 RS-422 TX) 1 = Half-duplex 8 RS-485 TXCVRS (RX & TX pairs tied) 2 = Reserved 3 = Reserved		J = Temperature Range and Coating 0 = Commercial (–5° to +45°C), No coating 1 = Commercial (–5° to +45°C), Humiseal 1A33 Polyurethane 2 = Commercial (–5° to +45°C), Humiseal 1B31 Acrylic 3 = Reserved 4 = Industrial (–20° to +70°C), Humiseal 1A33 Polyurethane 5 = Industrial (–20° to +70°C), Humiseal 1B31 Acrylic

Notes: *Both disks are identical and installed

Related Products

AMC516



- AMC FPGA carrier for FMC per VITA 57
- Xilinx Virtex-7 690T FPGA in FFG-1761 package with optional P2040
- Supported by DAQ Series™ data acquisition software

AMC530



- Altera Stratix IV Device EP4S100Gx in 1517 pin count (40 mm x 40 mm)
- On board PLL for buffering/multiplying and jitter cleaner
- Three banks of QDR-II+ each 72-bit wide

FMC210



- FPGA Mezzanine Card (FMC) per VITA 57
- Single ADC EV10AS150B @ 2.6 GSPS
- 5 GHz Full Power Input Bandwidth (–3dB)

Contact

VadaTech Corporate Office

198 N. Gibson Road, Henderson, NV 89014
Phone: +1 702 896-3337 | Fax: +1 702 896-0332

Asia Pacific Sales Office

7 Floor, No. 2, Wenhua Street, Neihu District, Taipei 114, Taiwan
Phone: +886-2-2627-7655 | Fax: +886-2-2627-7792

info@vadatech.com | www.vadatech.com

Europe: EMCOMO Solutions AG

Industriestr. 10, 89231 Neu-Ulm, Germany
Phone: +49 731 8803510 | Fax: +49 731 88035129

vadatech@emcomo.de | www.emcomo.de

Choose VadaTech

We are technology leaders

- First-to-market silicon
- Constant innovation
- Open systems expertise

We commit to our customers

- Partnerships power innovation
- Collaborative approach
- Mutual success

We deliver complexity

- Complete signal chain
- System management
- Configurable solutions

We manufacture in-house

- Agile production
- Accelerated deployment
- AS9100 accredited



vadatech
THE POWER OF VISION

Trademarks and Disclaimer

The VadaTech logo is a registered trademark of VadaTech, Inc. Other registered trademarks are the property of their respective owners. AdvancedTCA™ and the AdvancedMC™ logo are trademarks of the PCI Industrial Computers Manufacturers Group. All rights reserved. Specification subject to change without notice.

© 2019 VadaTech Incorporated. All rights reserved.
DOC NO. 4FM737-12 REV 01 | VERSION 1.1 – FEB/19